

# Application Notes

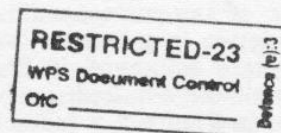

## MULTIPLEXED OPERATION OF NIXIE® TUBES

By: A. Somlyody; Manager, Applications Engineering

THERE ARE NOW TWO LOW-COST SERIES OF NIXIE® TUBES FOR TIME SHARING APPLICATIONS- B-5750 AND B-5850. AS SUCH ALL REFERENCES HEREIN TO B-5755 ALSO APPLY TO B-5855.

### INTRODUCTION

One definition given for the term "multiplexing" is "the utilization of a single device for several different purposes..." or according to Webster, the simultaneous sending of several messages over the same circuit. The "device" or "circuit" referred to in the above definitions is a common decoder and driver circuit which is used to drive from one to twenty (or more) NIXIE Indicators using time multiplexing techniques. Since the cost of the decoder-driver circuit is often 50 percent or more of the per digit cost of the display, significant savings on circuitry can be realized using a multiplexing technique.

Until recently, multiplexed or time-shared operation of NIXIE Indicators was not practically feasible because the high peak currents required, caused ionization to spread beyond the surface of the numeral to the leads and the pins. This extraneous glow within the tubes resulted in a generally poor aesthetic appearance of the display.

A tube, type B5755, recently developed by the Burroughs Corporation, overcomes all of the earlier difficulties and is intended specifically for use in time-shared applications.

This memorandum describes the general concept of NIXIE tube time-sharing in terms of block diagrams and timing requirements. It also deals with the specifications and characteristics of the B5755. Finally, some typical anode and cathode circuit examples are given.

### SYSTEM DESCRIPTION

When required to display a multi-digit number using NIXIE Indicators, it is entirely possible to energize the display one digit at a time, with each digit energized for only a short period of time, until all of the digits have been energized once. If this process is repeated continuously and at a sufficiently high rate, the display will appear as though all digits were energized continuously.

To achieve this visual effect, a sufficiently high refresh rate must be selected to prevent flicker effects. The term "refresh rate" applies to the pulse repetition rate of energizing any one given NIXIE Indicator in a multi-digit display. Generally, a 50 Hz, or higher, refresh rate gives good flicker free performance; however, in many situations, a lower refresh rate is usable.

If a numeric display has N digits, then each NIXIE Indicator can be energized at a duty factor of no greater than  $\frac{1}{N}$ . Consequently, the apparent brightness of the display lessens as the number of digits increases, unless some measure of brightness compensation is obtained. Since the light output of the NIXIE Indicator is proportional to the cathode current, the brightness compensation is achieved by using a higher current level when the tube is energized. This is entirely possible with the new type B5755 tube. At a duty factor of 5 percent and at an anode current of 15 mA, the type B5755 tube appears as bright as it would under normal d-c operation.

Figure 1 illustrates a simplified block diagram of a typical time multiplexed numeric NIXIE tube System. The system has a sequentially addressable word select memory with a capacity of N words where N is also the number of NIXIE Indicators in the system. Each word consists of at least four bits which represent, in binary form, the number of the corresponding decimal digit. The recirculation loop and the write circuits for the memory are not shown in Figure 1, but they would normally be required.

As shown in Figure 1, a four-bit word counter, triggered by the system Clock, drives a Digit Select Decoder. The outputs of the Digit Select Decoder are energized one at a time, stepping at a rate determined by the system Clock. These output lines sequentially drive the Memory Word Drivers, and the tube Anode Drivers one at a time. The Memory Word Drivers energize a word line in the Memory causing the corresponding four-bit word to be read by the Sense Amplifiers and stored in a four-bit BCD Register.

The output of the Digit Select Decoder which energizes a word driver is also applied to the cor-

responding tube Anode Driver. This Anode Driver turns "on," for one clock period, the NIXIE Indicator to which it is connected. During this clock period, the remaining N-1 NIXIE Indicators are held in the "off" condition by their Anode Drivers.

The output of the BCD Register is connected to the BCD To Decimal Decoder and tube Cathode Driver. The BCD word, which was read out of the Memory at the beginning of the clock period, appears as a signal on one of the ten cathode lines. The numeral corresponding to this cathode line becomes energized only in that NIXIE Indicator which also has a turned "on" Anode Driver.

On the next clock pulse, the Digit/Word Counter steps to the next state. This turns "off" output No. 1 of the Digit Select Decoder and turns "on" output No. 2. The corresponding word is again read out of the Memory, and the corresponding tube Anode Driver is energized. The new word that now appears in the BCD Register is that which is required to be displayed in tube No. 2.

It is easily seen how all N digits are displayed sequentially, with the proper information entering

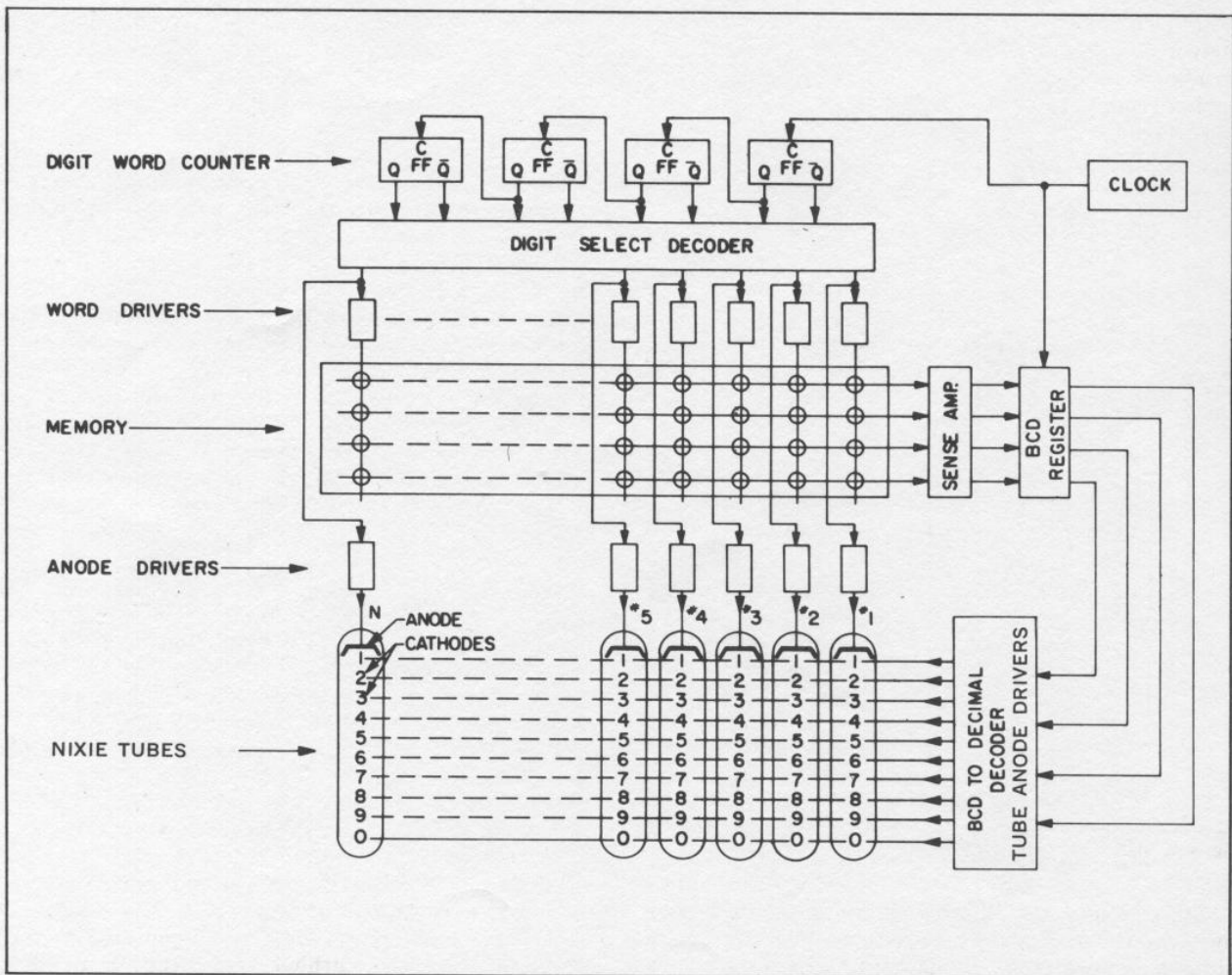

Figure 1. NIXIE TUBE TIME MULTIPLEXED DISPLAY SYSTEM, BLOCK DIAGRAM

the tube Cathode Drivers each time one of the Anode Drivers is energized.

When displaying an N digit number, as illustrated in Figure 1, the N words of the Memory are sequentially read out at a constant rate that is determined by the system Clock. Each time a word is read out, it is rewritten in the same position of the Memory, thus the information is preserved. When the displayed information is to be altered in one or more of the digit positions, the new information is written into the corresponding word position in the memory, just after the existing words are read.

As a further illustration of the operation of a multiplexed NIXIE tube, Figure 2 illustrates a timing diagram for an eight-digit system as it is displaying the number 75280016. Only the state of the tube Cathode and Anode Drivers is given and their time relation to the Clock. With reference to Figure 1, note that the NIXIE Indicators are energized in right to left sequence. Therefore, the number 75280016 is displayed by scanning from the least significant towards the most significant digits. In Figure 2, the Anode Drivers are energized sequentially for one clock period each. When Anode Driver No. 1 is energized, Cathode Driver No. 6 is also energized, thus displaying the number 6 in tube No. 1. Similarly, during the clock period from  $t_2$  to  $t_3$ , Anode Driver No. 2 and Cathode Driver No. 1 are energized.

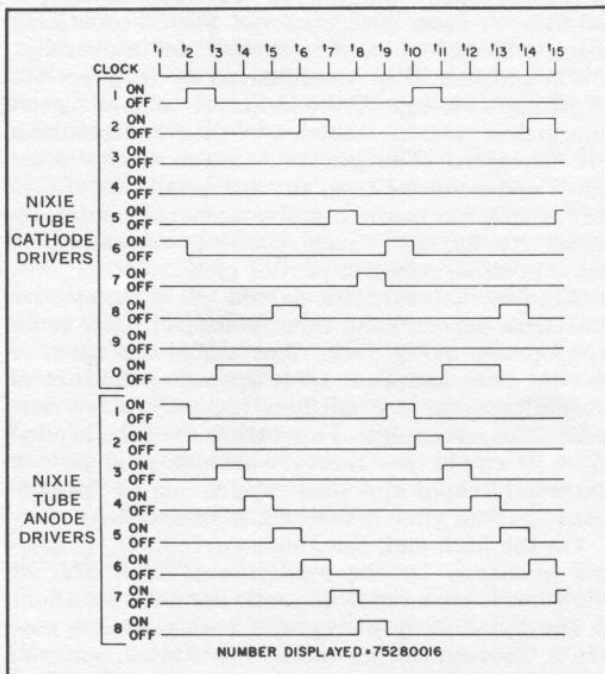

Figure 2. NIXIE TUBE TIME MULTIPLEXED DISPLAY SYSTEM, TIMING DIAGRAM

Since Figure 2 illustrates an 8-digit display system, the scanning cycle starts over again at time  $t_9$ , energizing Anode and Cathode Drivers one and six, respectively.

It is evident from the above discussion that a form of recirculating or sequential memory is an essential part of a time-shared NIXIE tube System. The number to be displayed must be stored somewhere and this storage medium must be interrogated repetitively. The potential economies of a time-shared NIXIE tube can only be achieved if such memory is already an essential part of the digital system whose output is to be visually displayed. Such typical digital systems might be desk calculators which generally utilize a delay line or some form of sequentially addressed dynamic memory as an essential part of the machine logic. The memory in such systems can also serve the secondary purpose of display refreshing.

If, as in the case of the calculator, the memory is already present as part of the logic, then the only additional components attributable to the NIXIE tube are the NIXIE Indicator tubes, the anode drivers (one for each indicator), and a decoder-cathode driver circuit. This results in a substantial cost savings particularly when the number of tubes approaches the upper limit of about twenty tubes per system.

For a non-multiplexed or d-c type of display, the entire content of the memory must be available simultaneously in terms of d-c levels, such as the outputs of the flip-flop registers. In many situations, besides such a d-c register, a dynamic register would still be required to perform serial arithmetic. In such systems, this dual storage requirement, in addition to separate decoder-cathode drivers for each NIXIE Indicator, make the d-c operation of NIXIE Indicators non-competitive.

There are other situations, however, where multiplexed operation would not be considered and where the d-c operation is the natural one. When the state of a multi-decade chain of counters is to be displayed continuously, the d-c operation is more economical. In this case, the counter already provides the d-c signal levels and each tube merely requires a decoder-cathode driver.

## NIXIE TUBE CHARACTERISTICS

The type B5755 NIXIE Indicator was designed for low duty cycle pulsed operation such as encountered in multiplexing applications. The tube is manufactured using somewhat higher gas pressures than other NIXIE tubes. The use of higher gas pressure for pulsed operation has several advantages:

- It reduces the total tube voltage drop, saving power and reducing the breakdown voltage requirement of the driver transistors.
- It reduces sputtering of the cathode, increasing the useful life of the tube.
- It causes the glow to be more confined to the vicinity of the cathode, resulting in a very sharply defined character.

When connected in a test circuit, such as shown in Figure 3, the tube can be represented by the equivalent circuit shown in Figure 4. In Figure 3, the "off" cathodes are disconnected and, therefore, under these conditions, the tube is a two terminal device. The corresponding equivalent circuit shown in Figure 4 is valid over any restricted anode current range within the limits of 2 mA to 20 mA. Within these limits,  $r_k$  is nonlinear, varying from approximately 8000 ohms at low currents to about 2000 ohms at high anode currents.

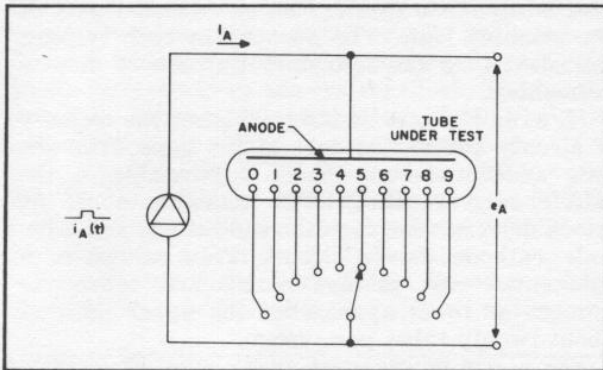

Figure 3. NIXIE TUBE TEST CIRCUIT, SCHEMATIC DIAGRAM

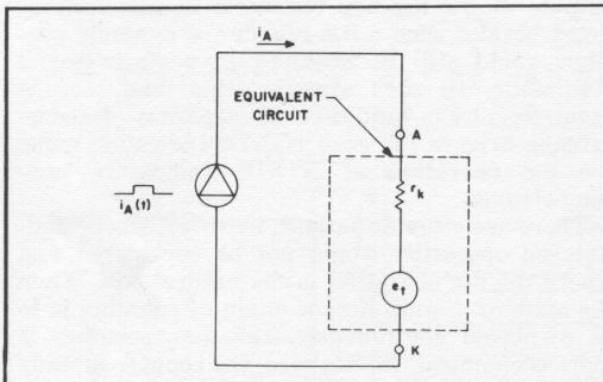

Figure 4. NIXIE TUBE EQUIVALENT CIRCUIT, SCHEMATIC DIAGRAM

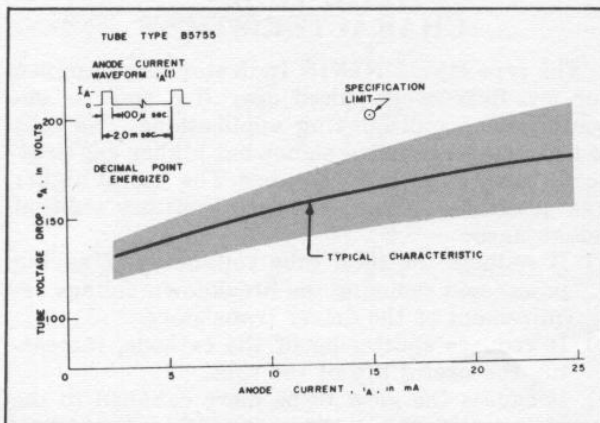

Figure 5. NIXIE TUBE, V-I CHARACTERISTICS

Usually, a linear approximation of  $r_k$  is adequate for any 2:1 range of anode currents.

Figure 5 shows typical anode voltage,  $e_A$ , versus anode current,  $i_A$ , characteristics of the type B5755 tube. This figure also gives some indication of the degree of spread of these curves among cathodes and among tubes. The curves shown in Figure 5 were plotted using the circuit shown in Figure 3. The forcing function is a current pulse of 100 microseconds duration with a 500 Hz repetition rate.

### TUBE SPECIFICATIONS

The electrical specifications for the type B5755 define the high voltage limit of the  $e_A - i_A$  characteristics at one point as indicated in Figure 5. The tubes, when energized with 15 mA anode current pulses under the timing conditions of Figure 5, will not exhibit a voltage drop greater than  $e_A = 200$  V. Knowing this one limit point and the approximate  $e_A - i_A$  curves, one can, by extrapolation, approximate the tube voltage drop for other anode currents.

The low limit of operating current is not defined in the specifications; however, operating the type B5755 below  $i_A = 5.0$  mA is not recommended. Generally, the low limit of usable anode current is determined by the formation of "partial glow." Partial glow or just "partial" is the term applied to the phenomenon whereby the glow does not cover the entire surface of the numeral shaped cathode. A more severe case of partial glow may cause difficulty in identifying the "on" numeral.

Partial glow may be enhanced by long periods of inactive storage of the indicator tube or by not energizing certain cathodes while other cathodes are energized. The latter condition causes some sputtered material from the energized numeral to be transferred to the inactive numeral, contaminating its surface. Such surface contamination may, in time, result in partial glow.

A tube that exhibits partial glow can be restored to normal condition by subjecting it to an appropriate aging cycle. The less severe cases of partial glow disappear after operating the tube at normal operating conditions for only a few seconds. The advantage of operating the tube around  $i_A = 15$  mA is that recovery from partial glow is extremely rapid and tube failure due to "permanent" partial glow is essentially nonexistent.

On the high end, the anode current,  $i_A$ , is limited primarily by the reduction of tube life. At high levels of cathode current, the active cathode is sputtered away more rapidly than at low currents. This sputtering causes the cathode material to vanish until the numeral breaks apart. Furthermore, the sputtered material deposits on the face of the tube reducing viewability. The rate of sputtering increases as the 3rd or higher order function of cathode current. Above  $i_A = 20$  mA, the effect of sputtering may reduce the tube life significantly.

## OFF CATHODE CHARACTERISTICS

An extensive discussion of "off" cathodes or "prebias" characteristics for NIXIE tubes may be found in Bulletin N102. The discussion in Bulletin N102 relates to d-c operation of the NIXIE Indicator, but with some change in values, the principles discussed there are still applicable under pulsed operation. In general, to minimize the slight glow in the vicinity of the "off" numerals, these cathodes must be maintained above a certain prebias voltage,  $E_{pb}$ , which for d-c operation of the B5750 (the subject tube of Bulletin N102) is about 60 volts.

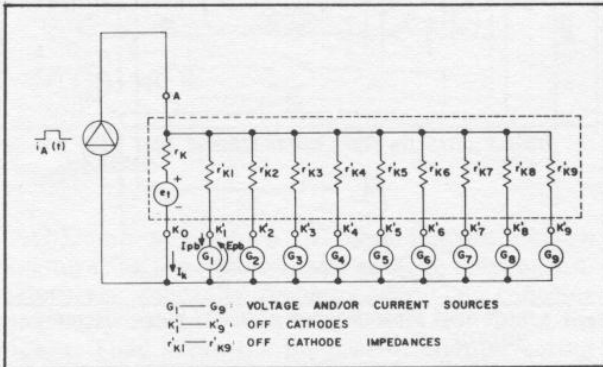

Figure 6. NIXIE TUBE EQUIVALENT CIRCUIT (INCLUDING ALL "OFF CATHODES") SCHEMATIC DIAGRAM

Figure 6 shows the equivalent circuit of a NIXIE Indicator when the "off" cathodes are not open circuited. Because of the resistance,  $r_k$ , the tube voltage drop increases with anode current and, at  $i_A = 15$  mA, the voltage drop may be as high as  $e_A = 200$  volts.

But for a given prebias voltage,  $E_{pb}$ , on the "off" cathodes a greater prebias current,  $i_{pb}$  results if the anode voltage,  $e_A$ , increases. This higher prebias current,  $i_{pb}$ , causes a more noticeable glow on the "off" numerals. Therefore, the conclusion is that for high-current pulsed operation, the NIXIE Indicator requires a higher prebias voltage to minimize "off" cathode glow. For a peak anode current of  $i_A = 15$  mA, the cathode driver transistors should have a minimum collector breakdown voltage of 100 volts. Integrated circuit drivers that have lower than 100 volts breakdown voltage, therefore, are not suitable for use in time-sharing systems.

## IONIZATION

Under normal room ambient light conditions, one generally does not experience any difficulty in ionizing a NIXIE Indicator either initially or repetitively. However, there are certain situations where the NIXIE Indicator may be operated either in a darkened environment, or placed behind a polaroid filter or other optical filter. Consequently, much of the radiation responsible for initial ionization is prevented from reaching the NIXIE Indicator. Under these conditions, and

after long periods of "off" time, the tube may require a relatively long period to ionize. The ionization time of a gas discharge device is, in general, a highly variable quantity which is dependent on factors such as:

1. Incident radiation at frequencies in the visible spectrum or above.
2. Availability of high velocity particles such as some radioactive sources or cosmic radiation.
3. Previous history of the device, that is, how long since it was last ionized.
4. Applied voltage between anode and cathode.
5. Rate of application of voltage.

By suitable combination of these factors, ionization times from less than one microsecond to many seconds have been observed. Various methods of circumventing the long ionization conditions have been developed which are used individually or collectively, as may be required. These are:

1. Addition of minute amounts of Krypton 85 radioactive gas.
2. Use of a keep-alive electrode to maintain a slight ionization in the tube at all times.
3. Use of higher than minimum voltage to energize the tube.

Each of these methods serves a distinctly different purpose.

Tubes containing radioactive gas are intended for use when the tubes must ionize in a totally dark environment. The requirement is that the tube ionize within a reasonable period of time after the application of the voltage. This time is generally well below one second and, for a tube having Krypton 85, time is usually specified as 50 milliseconds, maximum. The ionization of the tube, in this case, depends on the emission of alpha particles. For safety reasons, the relatively inactive gas, Krypton 85 is used. Time between emissions of particles which result in ionization of the gas is relatively long and is randomly distributed. The 50-millisecond ionization time for these tubes indicates that they cannot be relied on to ionize quickly if an "on" time of significantly less than 50 milliseconds is chosen for the tubes. When using very short duration anode pulses, it may take many applications of this anode pulse before coincidence occurs between the presence of anode voltage and the occurrence of an energetic ionizing particle. Under totally dark conditions and when the display is first turned on after a long "off" period, even the radioactive NIXIE Indicators may not ionize for some time when operated in a pulsed mode. This time delay may vary from a fraction of a second to several seconds. Such a delay may be annoying or intolerable. It should be noted, however, that under identical conditions, but using conventional non-radioactive NIXIE Indicators, the time to initial ionization of the display would be even longer. For these reasons, it is essential to use radioactive tubes whenever the display is required to turn "on" under totally dark conditions.

To minimize the delay for initial ionization of a multiplexed NIXIE tube, a small steady keep-alive current may be used. This keep-alive current is applied to any one of the 10 cathodes and is adjusted to a sufficiently low value, less than 10 microamperes, to prevent its presence from being objectionable to the observer. The keep-alive voltage assures the ionization of the radioactive tube within the 50-millisecond period since ionization is no longer dependent on the coincidence of the short duration anode pulse and the appearance of an ionizing particle.

The keep-alive circuit could take the form of a very high value (20 megohms) "pull-up" resistor either from the tube Anode to some positive high voltage, or it could be a "pull-down" resistor from one of the cathodes to a negative high voltage source. In either case, a diode must be used in the anode or the cathode circuit to isolate the keep-alive and drive circuits.

It is also possible to use this keep-alive technique in only one tube of a multi-tube display. Once this tube is energized, the total darkness is overcome and the radiation from this tube quickly ignites the remaining tubes in a display.

The use of a higher anode voltage is an additional aid in reducing ionization time. However, under totally dark conditions, a higher anode voltage will not serve as a substitute for a radioactive gas and a keep-alive current. Once the display has energized, the ionization time will be very short when the tube is being pulsed repetitively. If the anode supply voltage is 250 volts or higher, the ionization time will generally be less than 10 microseconds.

## TYPICAL CIRCUITS

The intent of this section is to discuss some typical cathode driver and anode driver circuits which may serve as a starting point in a system design. Compatibility with DTL or T<sup>2</sup>L levels was a prime consideration in these driver circuits. Typical circuits for the remainder of a system are not considered here since they are highly dependent on the overall system requirements.

### CATHODE DRIVERS

Figure 7 illustrates a decoder-driver circuit which uses 10 high-voltage NPN transistors, driven by DTL gates, which perform the decoding. Since the emitters of the high-voltage transistors are also driven by DTL gates, these gates must be capable of sinking slightly more than the full cathode current of the NIXIE tube.

Figure 8 shows a single package "one of 10 decoder," Fairchild CCSL9301, whose outputs drive 10 high-voltage NPN transistors. Again the CCSL9301 must sink slightly more than the full cathode current of the NIXIE tube.

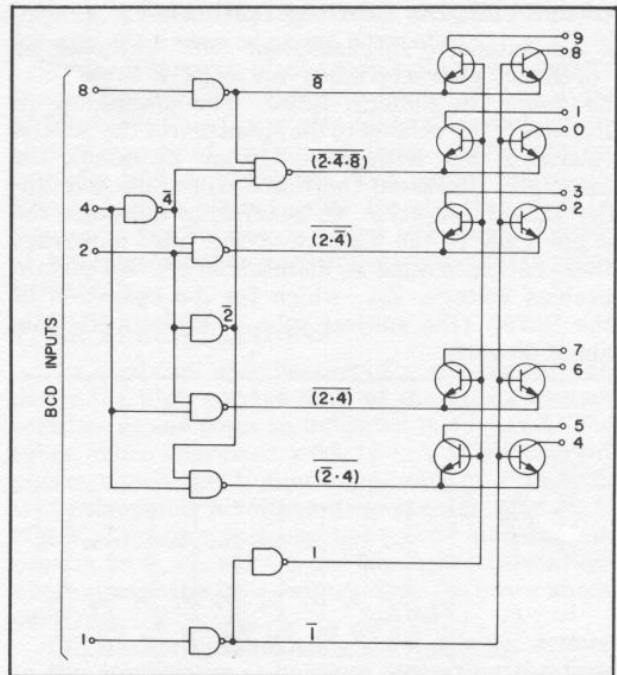

Figure 7. NIXIE TUBE DECODER-DRIVER USING DTL GATES, CIRCUIT DIAGRAM

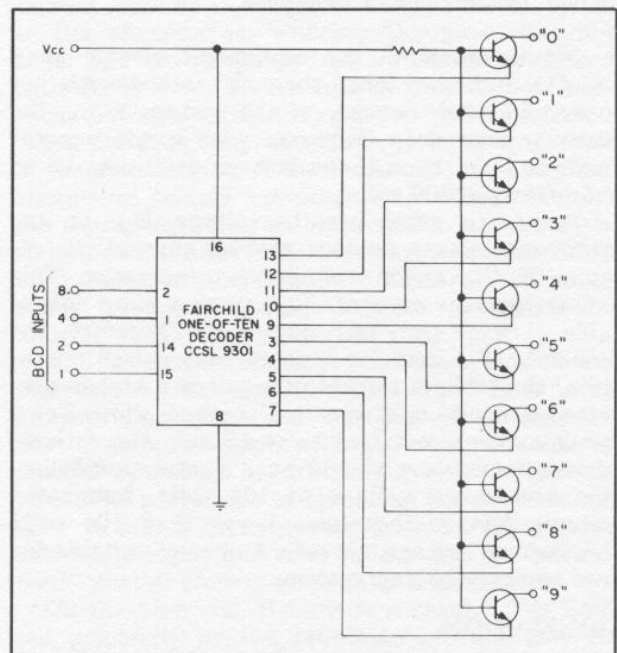

Figure 8. NIXIE TUBE DECODER-DRIVER USING A ONE-OF-TEN DECODER, CIRCUIT DIAGRAM

Figure 9 shows an RTL version of a decoder-driver circuit. In this case, only two of the gates are required to sink the full cathode current of the NIXIE tube. These gates are the ones in the even/odd control buss, connected to the 10 high-voltage NPN transistors.

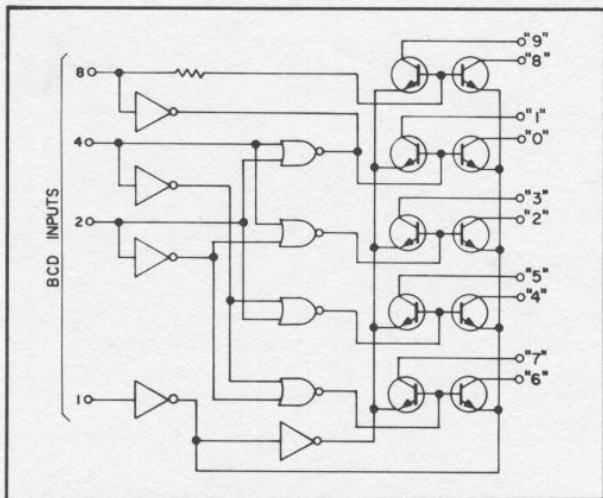

Figure 9. NIXIE TUBE DECODER-DRIVER USING RTL GATES, CIRCUIT DIAGRAM

Although not shown in these figures, pull-up resistors for the high-voltage cathode driver transistors are generally recommended. The collector resistors should be connected to +100 volts, or higher. They serve the purpose of counter-acting collector leakage current and also helping the turned off transistor collector to recover to a high potential in a shorter period of time. If the collector of the cathode driver transistor does not recover to approximately its quiescent positive potential by the time the next tube is turned "on," then the number will appear in the next tube faintly and give the appearance of a false indication. The value of the pull-up resistor will be dependent on the relative timing of new information arriving to the cathode drivers, new information arriving to the anode drivers, and also on the circuit wiring capacitances.

#### ANODE DRIVER

To energize the anode of a NIXIE tube, one has two basic choices: (1) To use a constant current source, or (2) to use a voltage source with an appropriate current limiting resistor. The objective is to maintain the anode current close to some predetermined value.

It seems that a constant current source is the ideal choice to meet the above objective. However, a transistor used for the current source may be required to dissipate considerable power.

If a voltage source is chosen with a current limiting resistor, then the supply voltage must be sufficiently higher than the maximum tube voltage drop to minimize variations in tube current. These current variations would result from variations in the tube drop, the supply voltage, and the value of the limiting resistor. Although the anode switch transistor dissipates little power since it can be operated in saturation, the breakdown voltage requirement increases.

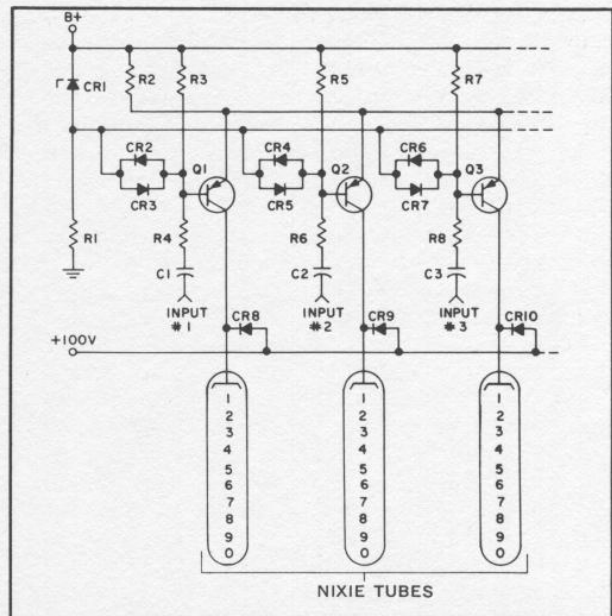

Figure 10. NIXIE TUBE CONSTANT CURRENT ANODE DRIVER, SCHEMATIC DIAGRAM

Figure 10 illustrates a typical constant current anode driver circuit. In this circuit, the B+ potential would be +200 volts or higher. It is chosen to just maintain the transistors outside of saturation when the worst case highest tube voltage drop occurs. The Zener diode, CR1, establishes a small voltage, perhaps 10 volts, below the B+ voltage. This small voltage, in conjunction with R2, determine the emitter current for the transistor which is turned on.

One of the transistors is turned on by the application of a negative pulse to the corresponding input terminal. If transistor Q1 is turned on, the values of R4 and C1 are chosen so as to maintain diode CR3 in conduction for the full period that Q1 is to remain in the on condition. This will cause the emitter of Q1 to be approximately at the potential of the anode of CR1. The  $V_{BE}$  drop of Q1 is balanced by the forward drop of CR3.

At the time the transistor Q1 is on, the remaining transistors, Q2, Q3, etc., are held in the off condition by resistors R5, R7, etc. These resistors cause CR4 and CR6 to become forward biased and thus maintain approximately 0.7 volts of reverse bias on Q2 and Q3.

It can be seen that the voltage swing required to turn one of these transistors on is equal to two diode forward drops. Therefore, it is quite possible to design the circuit to be compatible with DTL or T<sup>2</sup>L circuits.

The collectors of the constant current drivers are connected through catching diodes CR8, CR9, and CR10 to a +100 volt buss. This is done to prevent excessive voltages from appearing across these transistors. Without these diodes, overshoots would tend to occur due to the characteristics of the NIXIE tube.

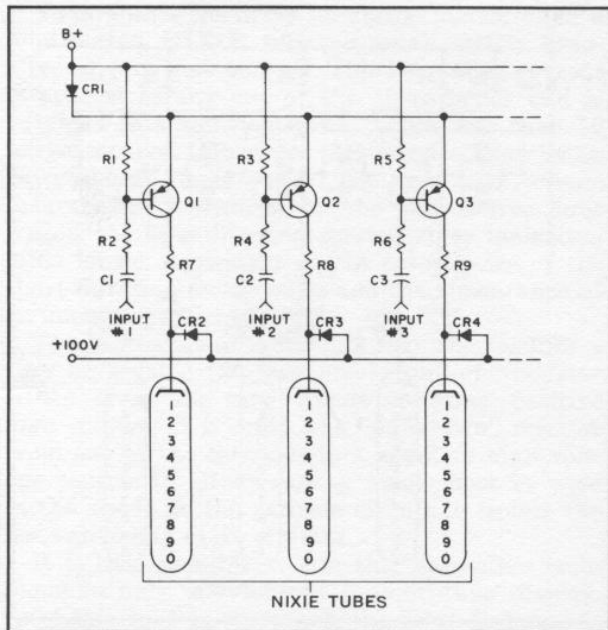

Figure 11. NIXIE TUBE CONSTANT VOLTAGE ANODE DRIVER, SCHEMATIC DIAGRAM

Figure 11 shows a constant voltage anode driver circuit. In the circuit, one of the transistors, Q1, Q2, Q3, etc., is turned on while the others are held off. Diode CR1, in conjunction with the base resistors, R1, R3, R5, serve to back-bias the off transistors. To turn transistor Q1 on, a negative pulse

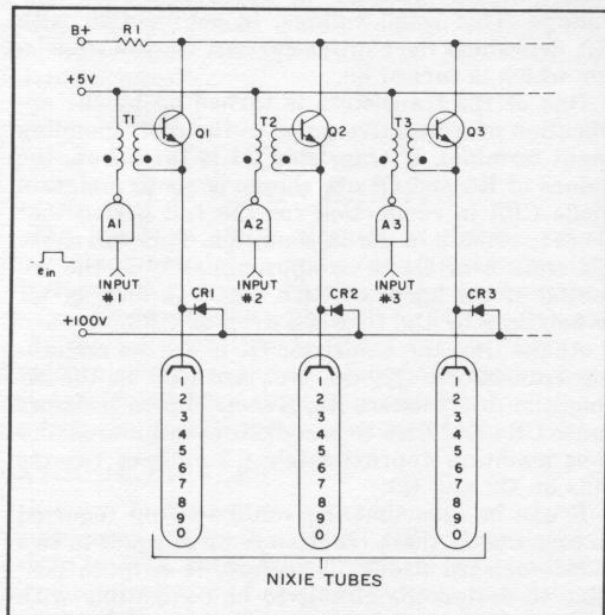

Figure 12. NIXIE TUBE TRANSFORMER-COUPLED ANODE DRIVER, SCHEMATIC DIAGRAM

is applied to input number one. The components R2 and C1 are chosen to maintain transistor Q1 in the on condition for the full period required by the system timing.

The purpose of the catching diodes, CR2, CR3, and CR4 is the same as in Figure 10. The anode driver circuits, shown in Figure 12, consist of high-voltage NPN transistor and pulse transformer, per digit. The pulse transformers couple the drive signal to the NPN transistors, which, in turn, switch one of the tube anodes to a common buss. Since only one transistor is on at any time, a common anode resistor can be used. The primary of these pulse transformers can be driven from any suitable integrated circuit gate.

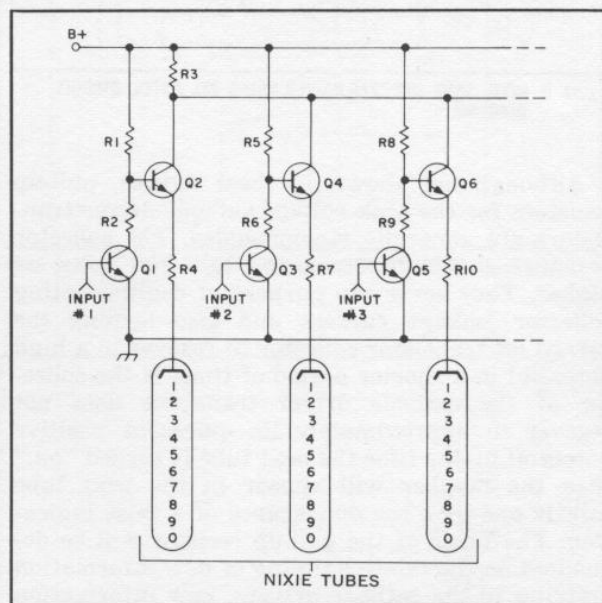

Figure 13. NIXIE TUBE TWO-TRANSISTOR ANODE DRIVER, SCHEMATIC DIAGRAM

Figure 13 illustrates a two transistor per tube anode driver circuit. Since high-voltage NPN transistors are still more readily available than high-voltage PNP devices, the cost of this circuit may compare favorably with the cost of some of the previous ones. Each of the control transistors, such as Q1, has a voltage divider in its collector circuit. When transistor Q1 is turned on, the voltage divider, consisting of R1 and R2, has a voltage at its mid point of approximately 100 volts. This causes the output of the emitter follower, Q2, to be at 100 volts and thus turn off the corresponding tube. When transistor Q1 is turned off, R1 supplies the current to the emitter follower, and consequently, Q2 turns on the NIXIE tube which is connected to its emitter.



Burroughs Corporation

ELECTRONIC COMPONENTS DIVISION  
PLAINFIELD, NEW JERSEY 07061

The information contained in this brochure does not necessarily imply a license under patents or pending applications of Burroughs Corp. or assure a freedom from patent rights of others. No warranties of any kind are either expressed or implied by reason of this publication.